

The Round Skew Chisel is a very useful tool for any woodturner. It is a great asset when doing any spindle turning work, whether large or small. Available in three sizes 1/4", 3/8" and 1/2" for fine miniature detail work through to large furniture pieces.

LATHE SET-UP

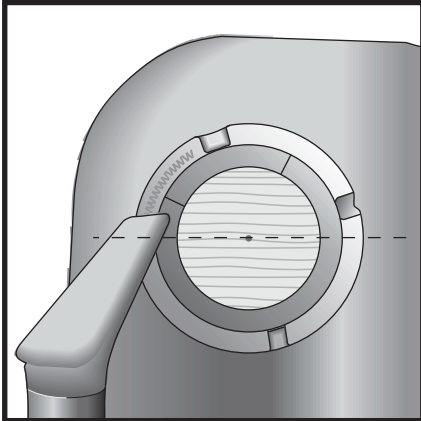

1. Position toolrest slightly above centre height.

TOOL USE

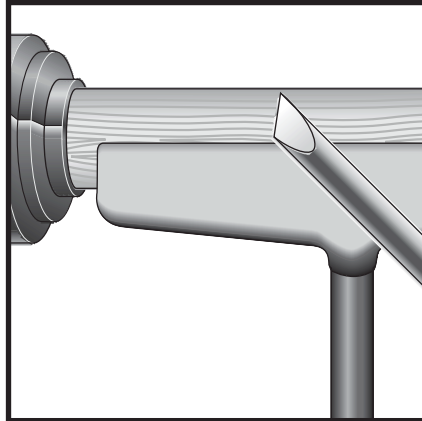

2. Place Round Skew on rest about 45° to the wood.

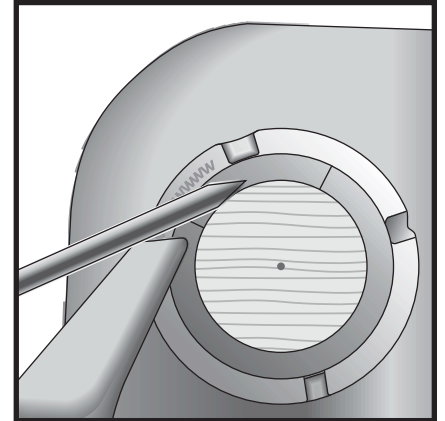

3. Approach the wood allowing the heel of the Round Skew to make contact.

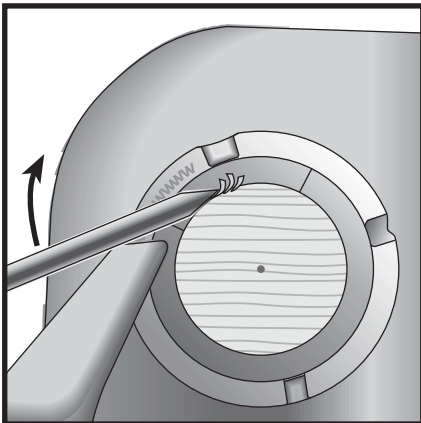

4. Raise handle slowly until you see shavings over cutting edge.

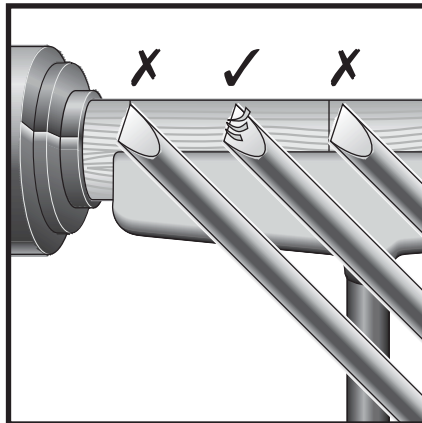

5. Always use the centre of the cutting edge.

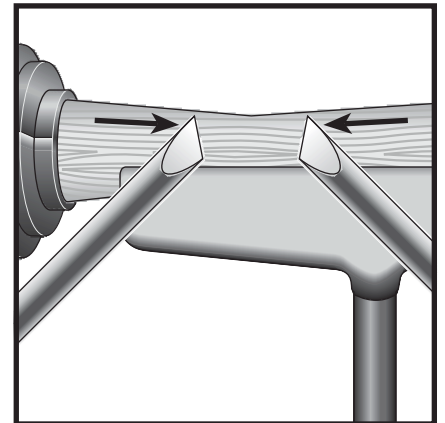

6. The Round Skew must be used to cut from large diameter to small diameter at all times.

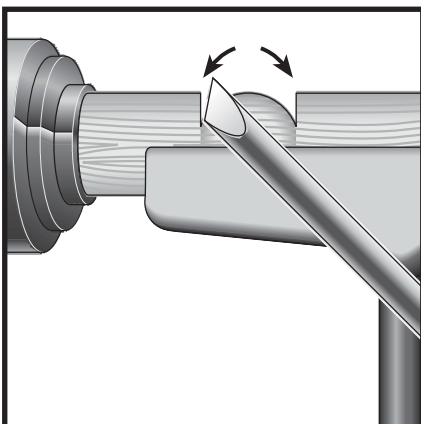

7. The Round Skew can also be used to produce beads.

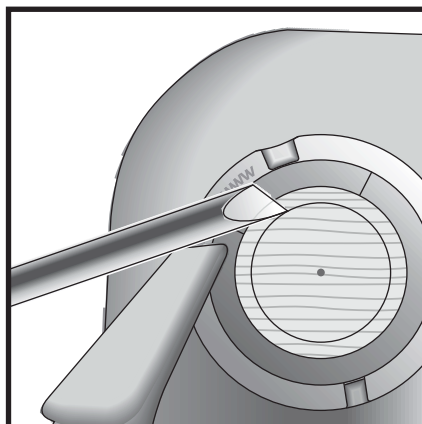

8. Use long point down to trace slicing cuts and to trim end grain.

SHARPENING

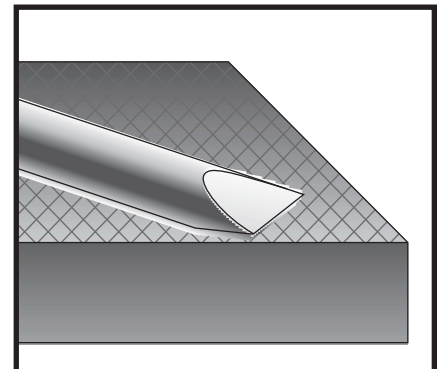

9. Sharpen the two flat faces of the Round Skew on a flat sharpening surface.

Robert Sorby Woodturning tools

As well as many specialist tools Robert Sorby manufactures in Sheffield a huge range of high quality HSS woodturning tools. Bowl and Spindle gouges are available with a standard grind in 1/4", 3/8", 1/2" & 3/4" Bowl gouges with a fingernail grind in 1/4", 3/8" & 1/2" and Spindle gouges with a fingernail profile in 3/8" & 1/2". Spindle Roughing gouges are manufactured in two sizes 3/4" & 1 1/4". Skew chisels come in several sizes and with standard, oval or round blades.

There is also a large selection of scrapers and parting tools to suit any woodturning project.

Robert Sorby also manufacture a range of micro tools to cover all those fine detail projects.

Sovereign Ultima Hollowing System small (Ref: SOV16S-ULTS) & Sovereign Ultima Hollowing System medium (REF: SOV22S-ULTM)

The Sovereign Ultima hollowing system from Robert Sorby has a high performance cutter system with "easy-clear" head design which allows for fast and effortless waste removal. Depth of cut can be finely tuned on the cut adjustment cap using the micro-adjust wheel. The multi-position and variable configuration head and link system allows the tool to be used in a variety of positions to create a multitude of hollow form shapes.

It is a hollowing system that allows the user to set the system to their requirements and produce beautiful hollow forms with ease. When used in conjunction with the Sovereign handle system which was introduced by Robert Sorby a little over a year ago it is the Ultimate hollowing tool for all woodturners.

The Sovereign Ultima system is available in two sizes. The small version is suitable for projects up to 11" in depth and is fitted to the 16" Sovereign handle. The medium model has a maximum hollowing depth of 16" and is fitted to the 22" Sovereign handle. Both systems include 3/8" & 1/2" collet adaptors to allow a large variety of other tools to be fitted.

Both sizes are also available as the Ultima hollowing tool without a handle.....blade only.

Sovereign 16" & Sovereign 22" System (Ref: SOV-16S & REF: SOV-22S)

The Sovereign is a handle system that gives the turners the ability to interchange a large range of gouges and other blades. The two lengths available give flexibility depending on the size of the project being worked and the length of the grip required. The high quality seamless steel tube gives strength and rigidity whilst the Softex grip gives a comfortable positive grip even when used for extended periods.

The head and end cap are machined from aircraft grade Aluminium with tool steel inserts in the head to ensure a long thread life of the brass tipped clamping screws.

Robert Sorby has chosen the materials and design of this handle without compromise to ensure maximum strength and feel, with extremely good vibration dampening properties.

As standard, both handles are designed to accept any tool with a 5/8" shank and the system includes two collet adaptors of 3/8" & 1/2". Also there is an optional addition of a 1/4" pilot bored collet adaptor to suit 1/4" blades that can also be drilled out by the user to a specifically required size.

Another optional extra is a counterweight that can be screwed into the end cap of both handles to help maintain the balance of the Sovereign when using heavier blades.

A thread coupler is also available to allow the turner to connect two handles together to produce a longer handle of a desired length of 32", 38" or 44".

Patriot lathe chuck (Ref: RSPC)

The all British manufactured patriot woodturning chuck is light, compact but incredibly robust and is perfect for any woodturning project. It has a smooth operating action in expansion and contraction with the one handed key. It is fitted with 2" (50mm) jaws which have an internal and external dovetail and gripper teeth for greater secure work holding. It is also supplied with a screw chuck and an insert to fit all available lathes on the market.

There is also a huge range of optional jaws and accessories available.

The ProEdge Ultimate Sharpening System (Ref: PE01A & PED01A)

The ProEdge from Robert Sorby represents the ultimate for sharpening any woodworking tools. Its unique design incorporates many years of experience in producing the keenest of edges accurately and efficiently. It is ready to use straight out of the box..... just plug it in and sharpen your tools! There is a selection of jigs to make it much easier to sharpen some of the more difficult tools, such as the Skew and Fingernail gouges.

The unique angle setter ensures the same sharpening angle is achieved with consistency and accuracy every time utilising the pre-set holes that takes seconds to adjust.

A variety of abrasive belts allow the correct material and grit to be used for the type of tool sharpening required. This is easily achieved with a quick and simple belt changing facility.

A FREE information and useage CD video is available upon request.

Modular Micro Tool System

This unique system is centred on the beautifully engineered burgundy anodised aluminium handle. Into this handle can be fitted an array of tools and blades.

There are four sets which are the Micro Sandmaster, Micro Spiralling tool, Micro Spindle set and Micro Hollowing set. The main benefit of this system is that the woodturner can buy just one of the handled sets and then add any of the unhandled tools, blades and heads from any of the other sets and the additional optional blades that are available.

Ideal for woodturners working on smaller projects.

Full details of our product range can be obtained from: Robert Sorby

Robert Sorby

Athol Road, Sheffield S8 0PA, England

Tel: +44 (0) 114 2250700 Fax: +44 (0) 114 2250710

Email: sales@robert-sorby.co.uk Website: www.robert-sorby.co.uk